



QC-10 and QC-20 Sound Calibrators

Operator's Manual



Thank you for choosing Quest Technologies to meet your calibration needs. To ensure the accuracy of your sound measuring instrumentation, Quest models QC-10 and QC-20 Calibrators provide quick, precise calibration. The instruments generate a stable acoustic signal at a controlled frequency and amplitude to verify the accuracy of sound level meters and noise dosimeters. It is our goal to make your decision to buy Quest products the right one, and to provide support for any questions or concerns that might arise.

The purpose of this manual is to provide the user with the necessary information to operate the QC-10 and QC-20 Sound Calibrators. The entire manual should be read to fully understand the many features this instrument offers.

This manual is not all inclusive and cannot cover all unique situations. In addition, no warranties are contained in this manual except as described under the warranty policy section.

Copyright 1999

Revision G

P/N 056-144



*The worldwide trusted name in
industrial hygiene instruments
for over 25 years*

1060 Corporate Center Drive • Oconomowoc, WI 53066 USA • 800-245-0779 • Fax: 414-567-4047
<http://quest-technologies.com>

Printed in U.S.A.

-j-

1. General Description.....	1
2. Theory of Operation	1
3. Operation Procedure.....	2
4. Altitude Effects	4
5. Microphone Corrections.....	4
6. Calibration Adapters.....	6
7. Examples of Calibrator Use	6
8. Battery Check and Replacement	7
9. Calibration	7
10. Specifications	9
11. Service Policy	11
12. Warranty Policy	12

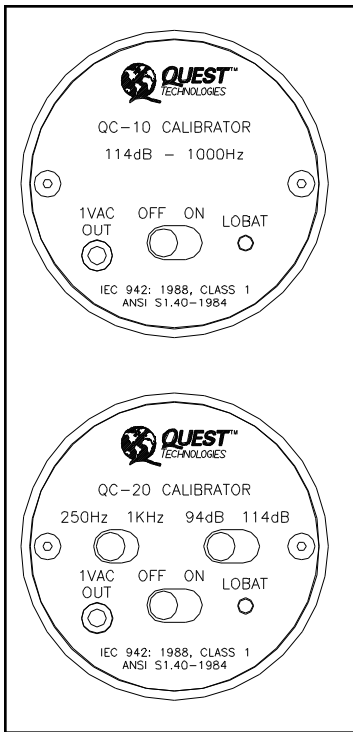

Figure 1.

1. GENERAL DESCRIPTION

The Quest Model QC-10 and QC-20 are acoustic calibrators for calibrating precision type 1 as well as general purpose type 2 sound level meters and other instrumentation with a microphone input. The QC-10 is a single frequency calibrator which generates 1000 Hz at 114 dB SPL. The QC-20 is a dual-frequency, dual-amplitude calibrator. It generates four selectable reference tones: frequencies of 250 and 1000 Hz, each at levels of 94 and 114 dB. The calibrators are powered by a single 9 volt battery.

The calibrators consist of an oscillator to generate the frequencies, an amplifier stage, a transducer and microphone coupler. The coupler directly accepts a standard 1" (15/16") diameter microphone. Separate adapters are available to accommodate other sizes of microphones. The calibrators also provide a 1 volt RMS signal through a 1/8" phone jack.

2. THEORY OF OPERATION

Figure 2 shows the basic functional blocks of the QC-10 and QC-20. The oscillator is a low distortion wein-bridge type with automatic gain control and temperature compensation for high stability. Precision capacitors and resistors control the frequency, and the amplitude of each frequency is individually adjustable for precise calibration of the SPL. The oscillator's output is fed through a temperature compensated driver circuit to the transducer where it is converted to sound pressure in the coupler cavity.

The battery test circuit compares the battery voltage to a reference voltage. If the battery is too low for proper operation, the circuit automatically disables the oscillator and no sound is produced. The red LOBAT light will indicate this condition.

3. OPERATING PROCEDURE

1. The coupler cavity of the calibrator is designed to directly accept a standard 1 inch diameter microphone (actual size is 15/16"). The proper adapter must be used for microphones whose diameter is less than 1 inch. Place this adapter into the coupler cavity with a slight twisting motion to ensure that it is fully seated. An O-ring will hold the adapter in place and provide an acoustic seal between the cavity and the adapter.

Note: If the calibrator has recently been moved from one area to another of substantially differing temperature (>10°C difference), it is advisable to allow 1/2 hour before attempting to calibrate equipment. This is to assure proper temperature stabilization of the equipment. The calibrator does not need to be "ON" during this period.

2. Carefully lower the calibrator over the microphone. If the adapter has an O-ring to provide a seal around the microphone, a slight twisting motion should be used to ensure proper seating of the microphone into the adapter. Take care not to unscrew the microphone while twisting.

Note: If the calibrator is not lowered slowly, damage to microphone diaphragms may result. Be sure the calibrator is seated squarely with the adapter and microphone or significant error may result.

3. Turn the unit on. Allow 15 seconds after turning on for the output to stabilize. If no sound is apparent after 15 seconds or the LOBAT light is lit, refer to the section on battery replacement (page 7).
4. QC-20 only: Select the frequency and amplitude desired. When selecting the frequency and amplitude combination, consider the following:
 - a. Background noise must be more than 20 dB below calibrator output for accurate readings, e.g., 74 dB or less for 94 dB position.
 - b. Meters with needle movement displays should typically be calibrated at or near full scale deflection.
 - c. Manufacturers usually state optimum frequency and amplitude for calibration of their instrument.

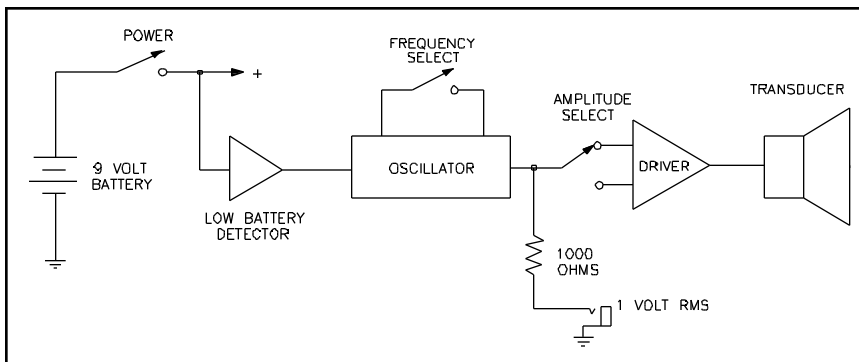

Figure 2. Calibrator Block Diagram

- d. The 250Hz tone is useful for checking the frequency response of instruments. When comparing meter response at 250 and 1000Hz with “A” weighting, the nominal reading at 250Hz should be 8.6 dB below the reading at 1000Hz. With “B” weighting, the reading should be 1.3 dB less. For both “C” and LINEAR (or FLAT) settings there should be no difference between readings at the two frequencies.
5. Verify the sound level meter’s accuracy by comparing its reading with the calibrator’s output. Following the manufacturer’s instructions, adjust the sound level meter for a correct reading. If attitudes or microphone corrections are necessary, refer to the most recent revision of ANSI S1.10.
6. After calibration is complete, slowly remove the calibrator, and switch off the unit. For further details of calibration, refer to the most recent revision of ANSI S1.10.
7. NEWER calibrators, beginning in 1998, have an automatic shutoff feature. This prevents draining the battery by accidentally leaving the calibrator turned on. A timer circuit will automatically shut the calibrator off after approximately two minutes. To restart the calibrator, turn the power switch OFF and then ON again.

4. ALTITUDE EFFECTS

Most calibrators are affected by changes in altitude and the resulting change in barometric pressure. The vibration of the calibrator's diaphragm causes cavity volume variations which thus cause pressure variations. Changes in ambient air pressure and density can change the actual sound level produced. The calibrators are set at the factory to produce their rated SPL at standard barometric pressure at sea level (760mm Hg).

Newer design calibrators, beginning in 1998, have negligible altitude correction requirements. The newer calibrators have a convex profile to the coupler cone, with a slightly extended "chimney" for the bleed hole.

Older calibrators, which have a straight conical profile to the coupler cone, require altitude compensation. Figure 3 shows correction factors for different altitudes and barometric pressures.

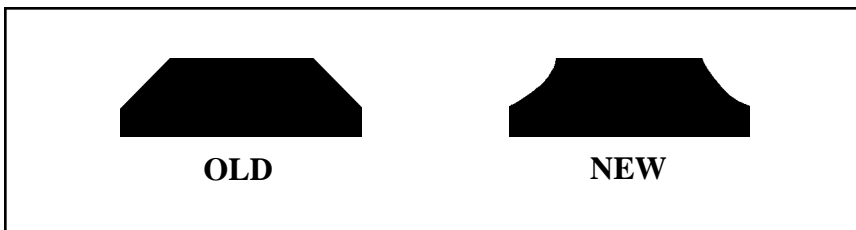

5. MICROPHONE CORRECTIONS

Different models of microphones have differing air volumes between the grid and diaphragm and also have diaphragms that vary in stiffness. Because of this, the generated sound pressure at the microphone diaphragm may vary from the nominal level of the calibrator. Also, free field microphones have reduced high frequency output when calibrated in a pressure chamber. A correction is thus necessary for some microphones.

Refer to the manual for your sound level meter or microphone for the proper correction values.

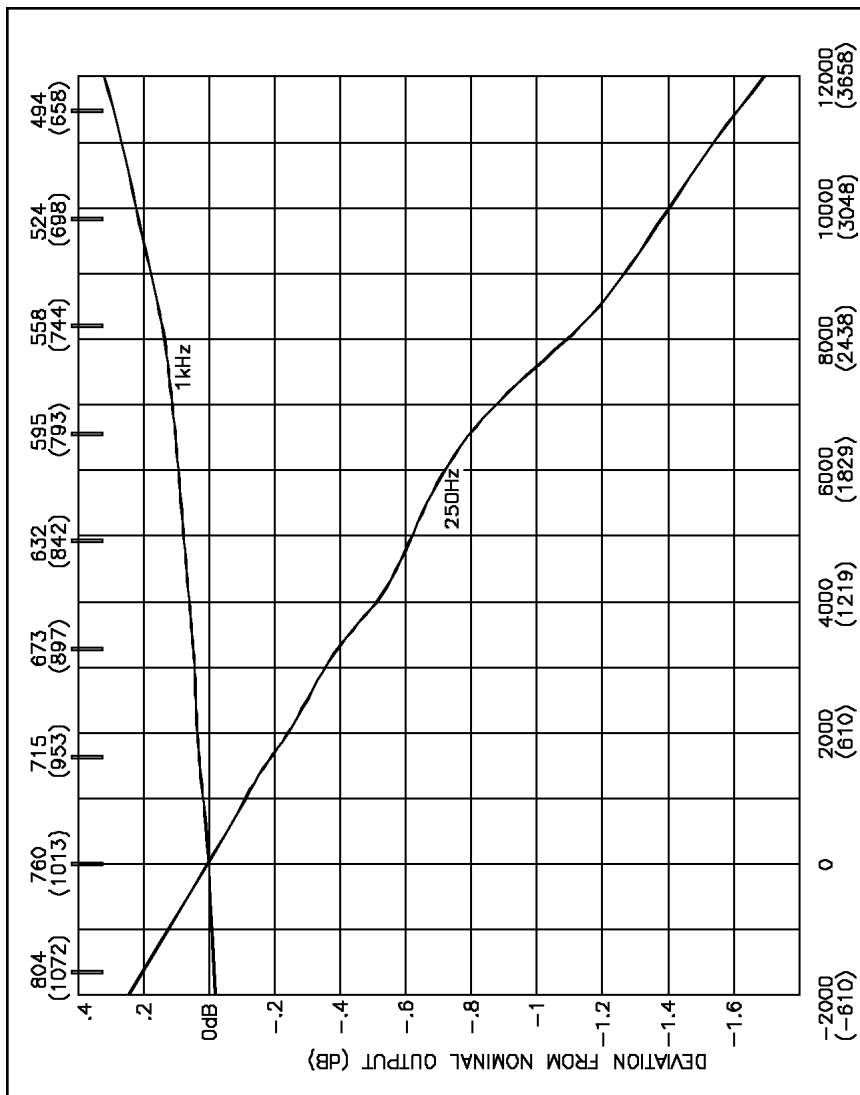

Figure 3. Effect of Altitude/Barometric Pressure

6. CALIBRATION ADAPTERS

The QC-10 and QC-20 cavity directly accepts a standard 1-inch measurement microphone (actual diameter 0.936"). Smaller microphones require an adapter for proper calibration. Quest provides the following adapters for various microphone sizes.

056-990	Standard 1/2 inch (0.52" actual) measurement microphone
056-988	Standard 1/4 inch diameter measurement microphone
056-989	Quest 8mm diameter dosimeter microphone
056-160	10mm diameter microphone for Quest model 208 meter
056-162	0.725 inch diameter microphone for Quest 261
056-163	0.827 inch diameter microphone used on older model Quest 2400/2500/2700/2800 meters

7. EXAMPLES OF CALIBRATOR USE

Example 1. You are calibrating a sound level meter with a 1/2" pressure response microphone which requires no correction. You are using an older design QC-20 at a barometric pressure of 530mm Hg, corresponding to an elevation of approximately 9,500 feet. With the calibrator set at 114 dB and 1000 Hz, the meter reading, from Figure 3, should be .2 dB above the calibrator setting, or 114.2 dB.

Example 2. You are checking a meter with a free-field microphone whose pressure response is 0.1 dB less at 250 Hz and 0.2 dB less at 1kHz than its free field response. You are using "A" frequency weighting at Denver, Colorado with an elevation of 5,200 feet. You are also using an older design QC-20 so altitude correction is required.

Set the calibrator at 1000 Hz and 94 dB. The microphone correction from the sound level meter manual states that the meter will read 0.2 or 93.8 dB. Also, from Figure 3 the altitude correction is +.1 dB. Therefore set the meter to read 93.9 dB.

As a check only, you may wish to switch the calibrator to 250 Hz. The corrections now are as follows:

"A" Weighting	-8.6 dB
Microphone	-.1 dB
Altitude	<u>-.6 dB</u>
Total	-9.3 dB

Check to see that the meter reads 84.7 dB ($94 - 9.3 = 84.7$).

8. BATTERY CHECK AND REPLACEMENT

No operator judgements are needed to determine the condition of the battery. If the battery is so low (approximately 7 volts) as to affect the unit's calibration, a battery-condition detector circuit disables the oscillator, lights the LOBAT indicator, and no sound is produced. Please note that the QC-10 and QC-20 have a circuitry stabilization time of 3 to 5 seconds, and no sound is produced during this time. This "warm-up" time should not be misconstrued as a low-battery condition. If, however, after 15 seconds no tone is heard, replace the battery with a fresh NEDA Type 1604 9 volt transistor battery. Newer units with the automatic shutoff feature will run for shorter lengths of time as the battery weakens.

To change the battery in newer units, remove the two screws in the cover plate. Remove the cover plate and metal sleeve to expose the battery. Pull the battery away from the snap connector and remove. To install a new battery, press its flat end into the foam retainer, compressing the foam. Slide the connector end of the battery in line with the battery socket and snap it into place. The battery will not "snap-in" in the wrong direction. Reinstall the sleeve, cover plate and screws.

To change the battery in older units, grasp the coupler (black cone) end in one hand and the gray sleeve in the other. Turn the sleeve counterclockwise until it can be slid off. When the sleeve has been removed, pull the battery away from the snap connector and remove. To install a new battery, press its flat end into the foam retainer, compressing the foam. Slide the connector end of the battery in line with the battery socket and snap it into place. The battery will not "snap-in" in the wrong direction. Reinstall the gray sleeve, making sure that it is firmly seated.

9. CALIBRATION

The QC-10 and QC-20 are calibrated at the Quest laboratory with a type L standard microphone (B&K 4144) and special instrumentation traceable to NIST. The QC-10 or QC-20 is very stable; but since it is used to calibrate other equipment, it should be checked periodically against laboratory standards. It is recommended that the calibrator be returned to the factory at least yearly for recalibration, or whenever there is a question as to its accuracy.

Figure 4 depicts the calibrator with the sleeve removed. Calibration is not affected by removing the sleeve. Calibration potentiometers are indicated for adjusting the SPL and the 1 volt output. The 1 volt adjustment is the master output adjustment and as such affects the SPL.

Note: These adjustments are for laboratory calibration only and should not be readjusted by the user.

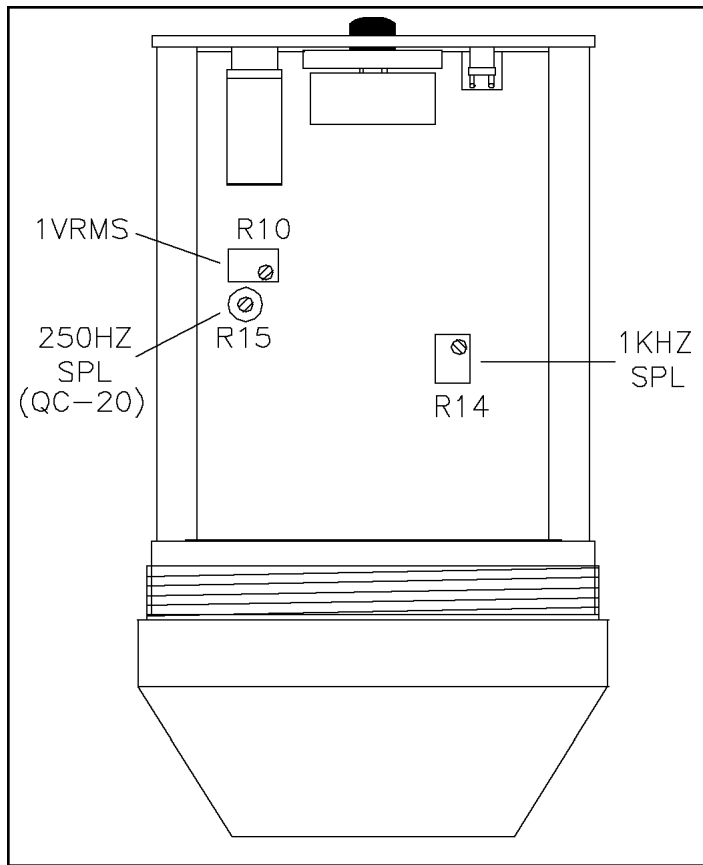

Figure 4. Calibrator Adjusting Potentiometers

8. SPECIFICATIONS:

Standards:	ANSI S1.40-1984 and IEC 942:1988 Class 1
Output Frequency:	QC-10: 1000 Hz QC-20: Selectable, 250 Hz, 1000 Hz \pm 2%
Output Amplitude:	QC-10: 114 dB QC-20: Selectable, 94 dB (1 pascal) or 114 dB ref. 20 μ N/m ² (20 μ Pa)
Output Accuracy:	\pm 0.3 dB @ 20°C 760mmHg
Distortion:	Less than 1% within temperature and humidity operating ranges
Electrical Output:	1 volt RMS sine wave, \pm 5% (0.4 dB) Output impedance = 1000 ohms. Phone jack (1/8") compatible with Switchcraft 780 plug or equivalent.
Temperature:	Operating range -10 to +50°C. 1 KHz: within \pm 0.3 dB from +5 to 50°C Below +5°C coefficient of SPL is 0.0 to +0.01 dB/°C ref. 20°C 250Hz: within \pm 0.3 dB from +5 to 40°C Below +5°C coefficient of SPL is 0 to 0.02 dB/°C max ref. 20°C Storage temperature -40 to +65°C with battery removed.
Coupler Volume Coefficient:	A 1cc increase in coupler volume will result in a typical decrease in output of .27 dB @ 1kHz and .67 dB @ 250 Hz.
Humidity:	Relative humidity 5 to 95% with less than 0.1 dB change in output.

Effects Due to
External Fields: 60Hz: No measurable effect up to 5 Oersted
(1 Oe = 80A/m)
400Hz: No measurable effect up to 2 Oersted
(Stated field strengths are magnetic test chamber
limits) Tested for RF susceptibility with no effect at
field strengths to 65 V/m over the frequency range
of 10MHz to 500MHz.

Power: Battery operated, 9 volt transistor battery, NEDA
1604 type. Projected battery life greater than 25
operating hours with intermittent use. Battery life is
affected by temperature. Consult battery manufac-
turer's data for specific battery life at a current draw
of 10mA.

Size: 4.1" (10.4 cm) long, 2.4" (6 cm) dia.

Weight: 12 oz. (0.35 kg)

QUEST SERVICE POLICY

Service Policy

The Quest product you have purchased is one of the finest acoustic instruments available. It is backed by our full one year warranty which seeks complete customer satisfaction. This is your assurance that you can expect prompt courteous service for your equipment from the entire Quest service organization.

Should your Quest equipment need to be returned for repair or recalibration, please contact the Service Department at (800)245-0779 (USA) or Fax (414)567-4047 for a Return Authorization Number. The RA number is valid for 30 days, and must be shown on the shipping label and purchase order/cover letter. If you are unable to return instruments in that time call for a new RA number. Send it prepaid and properly packed in the original shipping carton directly to Quest Technologies, 1060 Corporate Center Drive, Oconomowoc, WI 53066 U.S.A.

Repair or replacement work done under warranty will be performed free of charge, and the instrument will be returned to you prepaid. Your copy or a photocopy of the Quest Registration Card will serve as proof of warranty should the factory require this information.

If for any reason you should find it necessary to contact the factory regarding service or shipping damage, please direct your calls or letters to the attention of the Service Manager, Quest Technologies, (414) 567-9157 or (800) 245-0779. Office hours are from 7 AM to 6 PM (Central Standard Time) Monday through Friday.

For service or recalibration outside the U.S.A., please contact your local Quest Dealer or fax Quest U.S.A. at 1-414-567-4047.

QUEST WARRANTY POLICY

Warranty Policy

Quest Technologies warrants our instruments to be free from defects in materials and workmanship for one year under normal conditions of use and service. For U.S.A. customers we will replace or repair (our option) defective instruments at no charge, excluding batteries, abuse, misuse, alterations, physical damage, or instruments previously repaired by other than Quest Technologies. Microphones, sensors, and printers may have shorter warranty periods. This warranty states our total obligation in place of any other warranties expressed or implied. Our warranty does not include any liability or obligation directly resulting from any defective instrument or product or any associated damages, injuries, or property loss, including loss of use or measurement data.

For warranty outside the U.S.A., a minimum one year warranty applies to the same limitation and exceptions as above with service provided or arranged through the authorized Quest distributor or our Quest European Service Laboratory. Foreign purchasers should contact the local Quest distributor for details.



1060 Corporate Center Drive • Oconomowoc, WI 53066 USA
800-245-0779 • Fax: 414-567-4047 • <http://quest-technologies.com>
Printed in U.S.A.

056-144
Rev. G